



**NEW IN 2024**

# FIXLINE

*Solid, reliable and high-performance*

- Resistant to **chemical and salt corrosion, salt pool compatible**
- Shaft and mechanical seal in **AISI 316 stainless steel**
- **Self-priming pump** up to 3 m above water level
- Flow **rate up to 26m<sup>3</sup>/h** at 10m water column
- Test pressure of **3.5 bar (50 PSI)**
- Integrated thermal protection

**WARRANTY**

**3**  
YEARS

	Fixline 0,75	Fixline 1	Fixline 1,5	Fixline 2	Fixline 3
Flow (m <sup>3</sup> /h) à 10 m	12,2	16,5	21,2	24,2	26
Power consumption - P1	0,75 kW	1,1 kW	1,5 kW	1,8 kW	2,2 kW
Useful power - P2	0,75 cv	1,0 cv	1,5 cv	2,0 cv	2,5 cv



## Power & efficiency

The Fixline pump is the solution for optimising water circulation in your pool. This pump is designed to be powerful, guaranteeing efficient water filtration and circulation, essential for a clean, healthy pool.

Thanks to its robust design and high-quality components, **the Fixline pump is designed to operate reliably and for a long time, reducing long-term maintenance costs.**

## Technical information

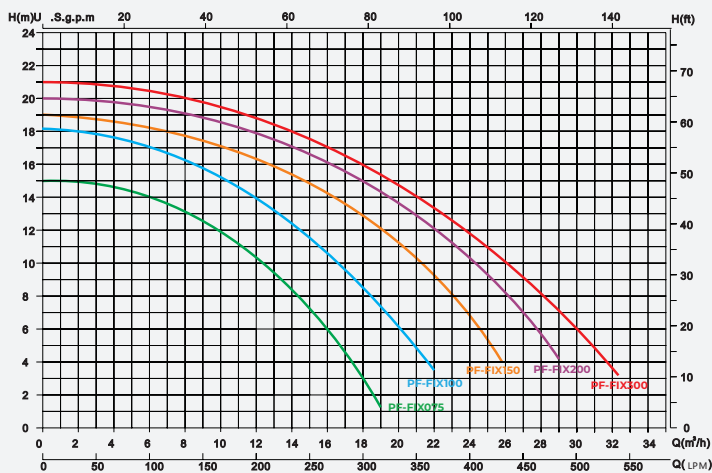

Note: The performance curve above is for 50Hz models.

### COMPACT SIZE

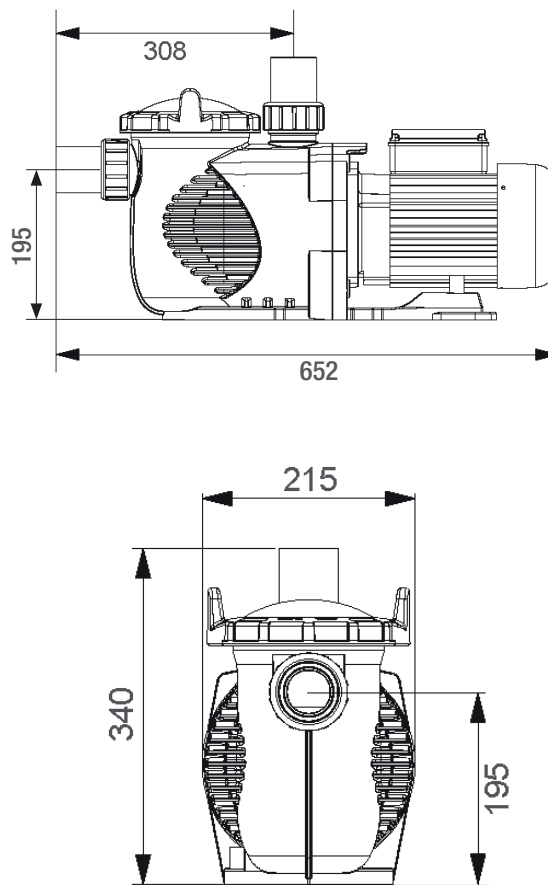

	Fixline 0,75	Fixline 1	Fixline 1,5	Fixline 2	Fixline 3
References	PF-FIX075	PF-FIX100	PF-FIX150	PF-FIX200	PF-FIX300
Power output (CV) - P2	0,75	1,00	1,50	2,00	2,50
Power consumption (kW) - P1	0,75	1,10	1,50	1,80	2,20
Intensity (AMP)	3,5	5	6,8	8,2	10
Noise (dB)	65		67		68
Connection diameter	1.5"x2" / 50 x 63 mm				
Engine type	Single-phase 230V 50Hz asynchronous 2-pole motor				
Flow at 10 mce	12,2	16,5	21,2	24,2	26
Test pressure	50 PSI (3,5 bar)				
Weights (kg)	13,6	13,8	14,0	14,2	14,5
Size in mm (L x l x h)	652 x 195 x 308				
Warranty	3 years				